



PowerPusher®

If It Rolls...We Can Move It.™

PowerPusher PT 1.2T™

Battery-Powered Material Handling Equipment

The **PowerPusher PT 1.2T™** is designed to promote productivity with minimal manpower by mobilizing up to 2,600 pounds with ease. The electrically powered PT 1.2T allows a single person to maneuver up to 2,600 pounds with total control.

- Moves up to 2,600 lbs. with push/pull capacity
- Improves operator safety
- Reduces manpower
- Increases plant floor productivity with less downtime
- Transports heavy loads fast and without strain



Quick-Change
Batteries



Tool-Free Height
Adjustable Coupler



Return To Straight Arm

NU-STAR, Inc.

powerpusher.com/800.800.9274



PowerPusher®

If It Rolls...We Can Move It.™



PowerPusher®
If It Rolls... We Can Move It.™

PowerPusher PT 1.2T™

Battery-Powered Material Handling Equipment

FEATURES & BENEFITS

- 24-Volt DC, 800W motor delivers up to 2,600 pound push/pull capacity
- Quick-change battery system
- Electric hydraulic weight transfer system
- Tool-free height adjustable coupler
- Emergency stop switch
- Anti-crush button
- Return to straight arm
- Ergonomic handles are height and angle adjustable
- Free Wheel Mode allows you to move without power
- Electromagnetic parking brake



MACHINE SPECIFICATIONS	
Push/Pull Capacity:	Up to 2,600 lb. push/pull
Motor Type:	24 Volt 800 W
Max Speed:	2.5 mph
Charging Specifications:	115V, 5 amp
Battery Life:	Up to 5 miles
Battery Capacity:	20 AH

OPTIONS

- Audible Beeper
- Spare Battery Pack
- Safety Strobe
- Custom Attachments

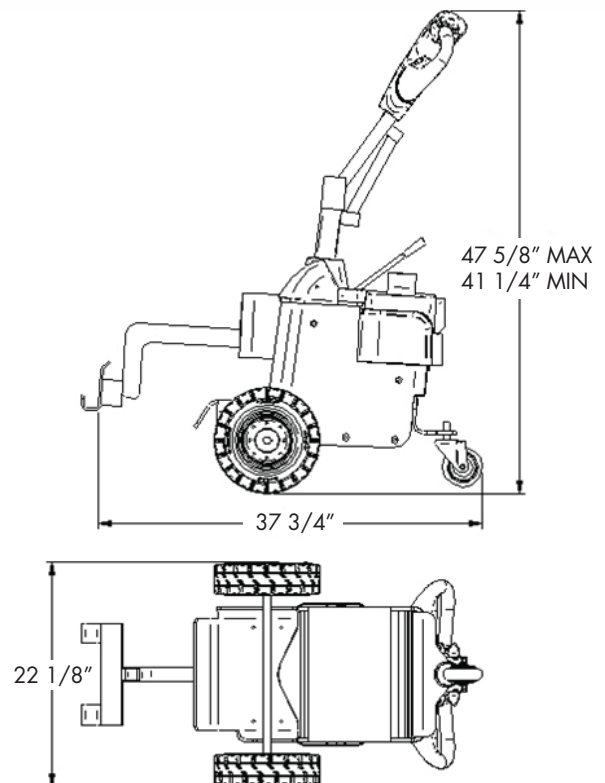
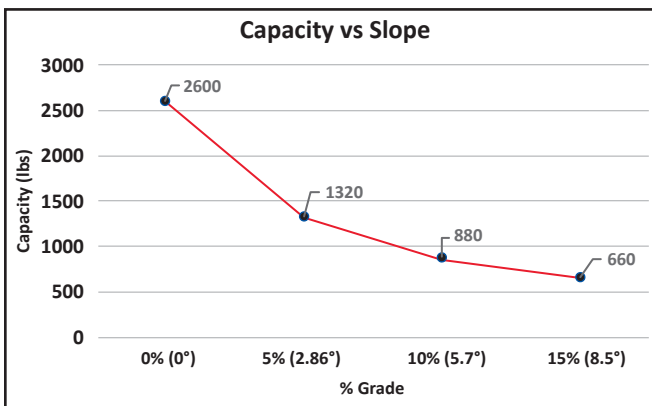

1425 Stagecoach Road, Shakopee, MN 55379
Phone: 952.445.8295



PowerPusher®
If It Rolls... We Can Move It.™

powerpusher.com/800.800.9274